

Technical data sheet

Product features



Fry-top griddle plate combined

Model

SAP Code

00013578



- Top type: Combined
- Griddle dimensions [mm x mm]: 800 x 800
- Griddle thickness [mm]: 14.00
- Worktop material: Stainless steel
- Grid size [mm x mm]: 680 x 760
- Container for liquid fat: Yes
- Independent heating zones: Separate control for each heating zone
- Maximum device temperature [°C]: 300
- Removable rim: Yes

SAP Code	00013578	Loading	400 V / 3N - 50 Hz
Net Width [mm]	800	Griddle dimensions [mm x mm]	800 x 800
Net Depth [mm]	800	Grid size [mm x mm]	680 x 760
Net Height [mm]	220	Top type	Combined
Net Weight [kg]	80.00	Worktop type	Molded - comfortable cleaning maintenance
Power electric [kW]	15.000		

Technical data sheet

Technical drawing



Fry-top griddle plate combined

Model

SAP Code

00013578

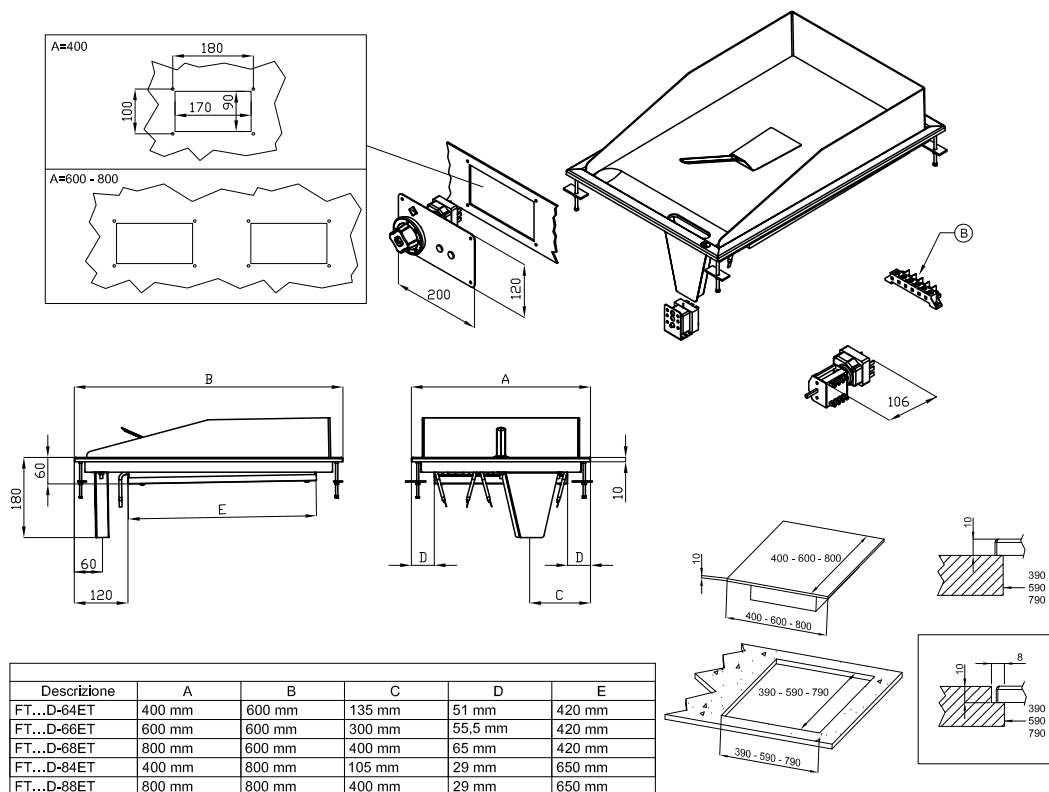

A	Data plate		B	Electrical connection	
---	------------	--	---	-----------------------	--

Technical data sheet

Technical parameters



Fry-top griddle plate combined

Model

SAP Code

00013578

1. SAP Code:

00013578

2. Net Width [mm]:

800

3. Net Depth [mm]:

800

4. Net Height [mm]:

220

5. Net Weight [kg]:

80.00

6. Gross Width [mm]:

830

7. Gross depth [mm]:

970

8. Gross Height [mm]:

540

9. Gross Weight [kg]:

90.00

10. Device type:

Electric unit

11. Construction type of device:

Drop-in

12. Power electric [kW]:

15.000

13. Loading:

400 V / 3N - 50 Hz

14. Protection of controls:

IPX5

15. Exterior color of the device:

Stainless steel

16. Material:

Stainless steel

17. Indicators:

operation and warm-up

18. Worktop type:

Molded - comfortable cleaning maintenance

19. Worktop material:

Stainless steel

20. Worktop Thickness [mm]:

14.00

21. Standard equipment for device:

comes with a stainless steel scraper for cleaning pastries

22. Maximum device temperature [°C]:

300

23. Minimum device temperature [°C]:

50

24. Service accessibility:

Trough the frontal panel

25. Safety thermostat:

Yes

26. Griddle dimensions [mm x mm]:

800 x 800

27. Griddle thickness [mm]:

14.00

28. Container for liquid fat:

Yes

Technical data sheet

Technical parameters



Fry-top griddle plate combined

Model

SAP Code

00013578

29. Independent heating zones:

Separate control for each heating zone

31. Grid size [mm x mm]:

680 x 760

30. Removable rim:

Yes

32. Top type:

Combinated